

# Challenger Global 300 - Power Plant

## INTRODUCTION

The Challenger 300 is equipped with two Honeywell AS907 high-bypass turbofans. Each powerplant is controlled by a full authority digital engine control system (FADEC).

The AS907 turbofan engine is a 4.2 bypass ratio, two-spool direct drive turbofan engine. The single-stage, wide-chord fan is directly driven by a three-stage low-pressure turbine. The core consists of a four-stage-axial compressor with two stages of variable geometry, a single stage of centrifugal compressor, a through-flow annular combustor, 16 fuel nozzles, 2 ignitors and a two-stage high-pressure turbine. Exhaust system includes an exit guide vane, a mixer nozzle and a centerbody. The accessory gearbox mounts the engine air turbine starter and provides accessory drive pads for mounting the hydraulic pump and generator, as well as providing lubrication for the engine.

## FLAT-RATED THRUST

Outside air temperature and pressure altitude are determining factors in achieving takeoff power. Increases in ambient temperature or pressure altitude adversely affect the engine's ability to produce rated thrust. Normal takeoff thrust rating is 6826 pounds. The AS907 is flat rated to ISA +15 °C (86 °F) at sea level. Automatic power reserve (APR) provides flat rated takeoff thrust to ISA + 20 °C (95 °F). APR is invoked either during one engine inoperative condition, with TLA at or above takeoff detent and APR armed, or when the throttle is pushed to the forward mechanical stop.

## HONEYWELL AS907 ENGINE SECTIONS

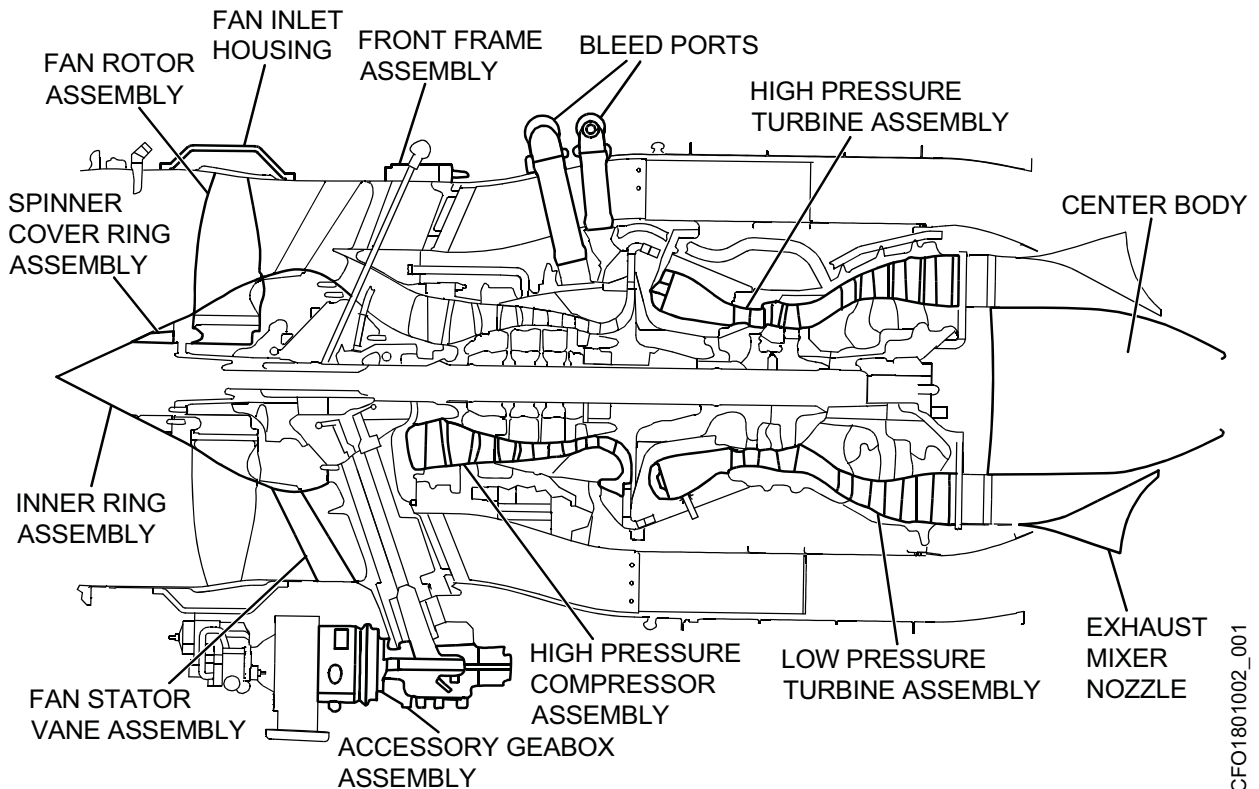

## ENGINE CONSTRUCTION

### DESCRIPTION

The AS907 powerplant has two independent major assemblies. The N1 section consists of a fan rotor that is driven through a shaft by a three stage low-pressure turbine. The N2 section is comprised of four axial flow and one centrifugal compressor, combustor, accessory gearbox and a two stage high pressure turbine. The high pressure turbine drives the compressor.

### AIRFLOW PATHS

Inlet air is initially accelerated and compressed by the fan and is split into two streams. A large percentage of the fan air exits into the bypass duct. The remainder is directed into the core of the engine. This core airflow passes through a four stage axial compressor and a single stage centrifugal compressor. Exiting the high pressure compressor diffuser the airflow is directed into the in line annular combustor where fuel is injected. The fuel/air mixture is ignited and a continuous combustion is maintained. The expanding gases are then directed through the two stage high pressure and three stage intermediate turbine assembly, driving both rotating groups, and exiting the engine through the mixer nozzle.

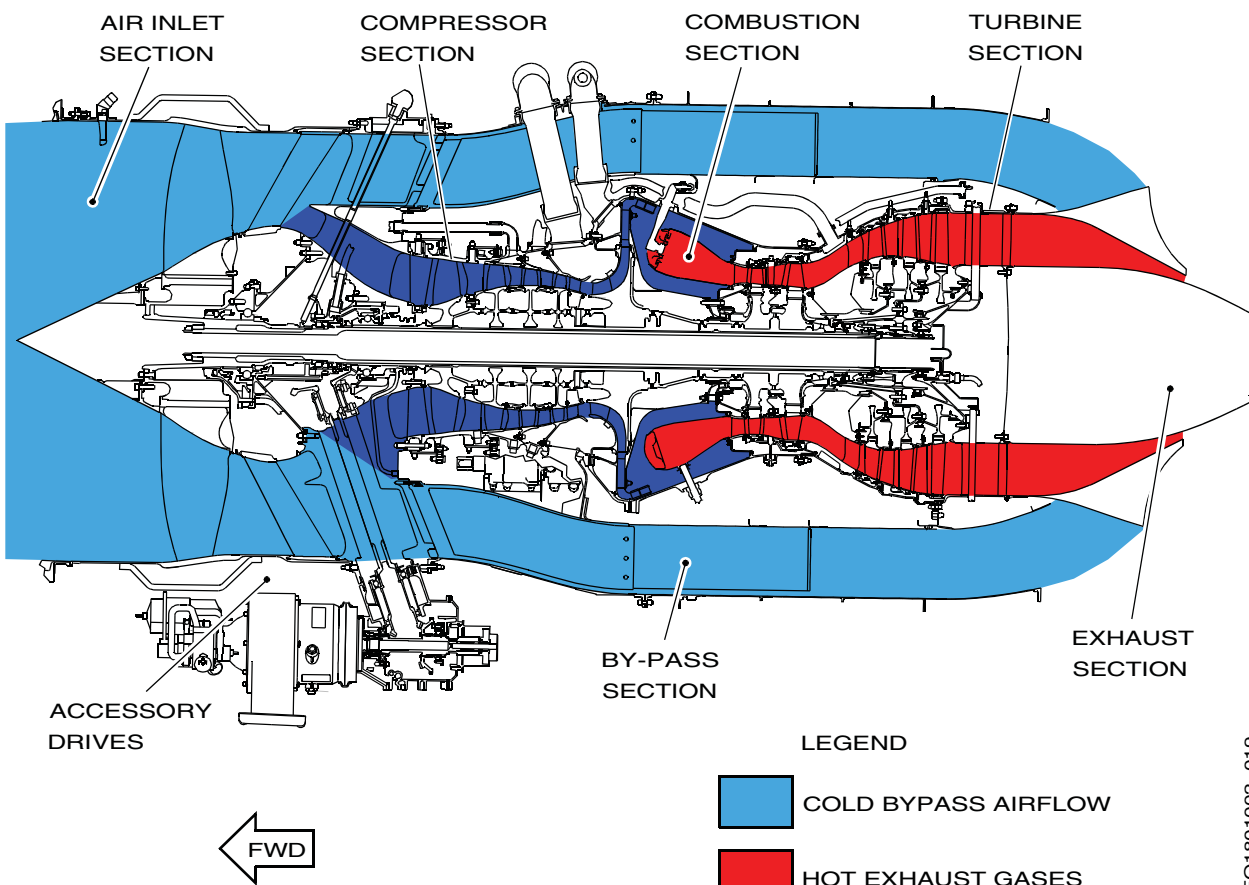

CFO1801002\_019

## ENGINE CONSTRUCTION (CONT)

### MAJOR POWERPLANT COMPONENTS

#### N1 FAN

N1 fan consists of twenty two titanium inserted blades. the fan containment system uses an aluminum honeycomb material surrounded by an aramid fiber wrap.

N1 fan speed is indicated on the EICAS.

#### N2 COMPRESSOR

The N2 compressor is a variable geometry (VG) axial flow compressor that is mechanically driven by the high-pressure turbine assembly.

The variable geometry (VG) system regulates airflow across the N2 compressor by changing the position of the inlet guide vanes and the stator vane for the inlet and first stage of the compressor. The VG system optimizes the angle of attack of the airflow at the compressor blades and provides compressor stall and surge protection.

The VG inlet guide vanes and stators are programmed by FADEC and positioned by actuators and mechanical linkage. High-pressure fuel from the engine fuel metering unit is used to hydraulically move the actuators.

N2 speed is displayed on the EICAS. There is no EICAS indication for the variable geometry system.

#### ACCESSORY GEARBOX

The N2 compressor drives the engine accessory gearbox. Mounted on the gearbox are:

- Engine lubrication pumps
- Hydraulic pump (EDP 1 or EDP 2)
- Engine fuel pump and fuel metering unit (FMU)
- Air turbine starter
- Integral oil reservoir
- Generator
- Permanent Magnet Alternator (PMA)

The PMA provides three-phase power to each engine control unit (ECU). The ECU measures N2 from one of the three phase inputs. The PMA is designed to provide the electric power required by the control system and engine at and above 45% N2. This speed is less than the minimum N2 idle speed. The PMA is considered to be the primary source of ECU power, with 28 VDC from the aircraft being the backup source. Aircraft 28 VDC power is required for starting and shutdown.

## ENGINE FUEL SYSTEM

### DESCRIPTION

Fuel is delivered to the fuel injectors at the pressures and flow rates necessary to maintain the desired engine thrust. The engine fuel system also performs the following functions:

- Compressor variable geometry actuator.
- Cool the engine oil (heat transfer).
- Actuate and lubricate fuel system components.
- Provide motive flow for the scavenge and main ejector pumps.

Combustion fuel can be interrupted by moving the L (R) ENGINE run switches to STOP or by selecting the L (R) ENGINE FIRE switches. The STOP position shuts off the fuel at the fuel metering unit. The L (R) ENGINE FIRE switch closes the fuel shutoff valve and the fuel metering valve shutoff valve.

### COMPONENTS AND OPERATION

#### FUEL PUMP

The fuel pump mounted on the accessory gearbox is comprised of three separate pumps contained within a single housing. The fuel pump provides fuel under high pressure and at flow rate that exceeds the requirements of the engine at any power setting. Excess fuel is bypassed back through the fuel filter system for re-circulation.

Fuel pump pressure is also used to generate motive flow for the scavenge and main ejectors of the aircraft fuel system.

#### FUEL/OIL HEAT EXCHANGER AND FUEL FILTER

A fuel/oil heat exchanger warms engine fuel and cools engine oil. The engine fuel temperature is indicated on the FUEL synoptic page.

A 10 micron fuel filter is used to remove solid contaminants from the fuel. The filter is depicted on the FUEL synoptic page. An impending fuel filter bypass condition on either engine is reported by an advisory CAS message L(R) ENGINE FUEL BYPASS. A dual impending fuel filter bypass condition on both engines is reported by a caution CAS message (ENGINES FUEL BYPASS).

#### FUEL METERING UNIT

The fuel metering unit (FMU) is an electrohydraulic device that meters and distributes the fuel needed for combustion based upon control signals from the FADEC system. The FMU's primary components are the fuel metering valve and pressurizing and shutoff valve. The metering valve supplies fuel in response to commands from the FADEC to maintain combustion under all operating conditions. The pressurizing and shutoff valve controls the supply of fuel for combustion.

The FMU also supplies the high-pressure fuel to actuate the VG inlet guide vanes and compressor stator vanes.

#### FUEL SYSTEM OPERATION

The main fuel ejectors or DC powered boost pumps deliver fuel from the collector tanks via fuel feed manifolds to the engines. Engine fuel shutoff valves (SOVs) are installed in the manifold to interrupt the supply of fuel to the engines during a fire. The L (R) ENGINE FIRE switches control the SOVs.

At the engine, the fuel is pressurized, heated, filtered, metered, and distributed to the combustion chamber. All fuel scheduling is controlled by the FADEC.

# Challenger Global 300 - Power Plant

## ENGINE CONTROL SYSTEM

### DESCRIPTION

The Honeywell AS907 powerplant is controlled by the full authority digital electronic control (FADEC) system. The FADEC provides a full range of engine control, including thrust reverser control under all steady state and transient engine conditions. The FADEC controls the operation and performance of the engine through three subsystems: fuel control, compressor airflow management, and engine starting/ignition control.

### COMPONENTS AND OPERATION

#### FADEC UNIT

Critical functions of the FADEC include:

- Control of engine thrust within the required limits, including control of bleed valves, compressor guide vanes (CGVs), and nacelle anti-ice bleed flow
- Validates N1, N1 limits, and interstage turbine temperature (ITT)
- Thrust reverser operation
- Overspeed circuits

Each powerplant has its own dual-channel FADEC computer. One FADEC channel operates as the in-control channel and processes information to provide engine control outputs. The other channel operates in standby. The standby channel processes all the input information but does not provide control output with one exception. Both the in-control and standby channels will respond to an engine overspeed by commanding the shutoff valve in the fuel metering unit to close in order to return the engine to an on-speed condition.

The in-control and standby channels continuously share command and status data through a crosstalk data bus. Should the designated in control channel become unserviceable, the standby channel assumes the in control role.

During normal operations with two serviceable FADEC channels, FADEC software directs the channels to alternate in-control and standby roles on each successive engine start.

FADEC malfunctions are presented as either caution or advisory messages. Each message has a different impact on the dispatch ability of the aircraft.

#### ELECTRICAL POWER

The PMA ensures FADEC supply when N2 is greater than 45%. For engine starting and whenever N2 is below 45%, the aircraft electrical system supplies power to the FADEC system.

#### ENGINE IDLE

When the thrust lever is placed at IDLE, the minimum N2 idle rpm is programmed by the FADEC. Idle rpm is dependent upon atmospheric information, bleed-air loading and phase of flight.

The FADEC will always program the best idle speed for any phase of flight. When the aircraft transitions from one flight phase to the next, idle rpm is automatically adjusted. There are three different N2 idle settings: flight idle, reverse idle, and ground idle.

#### FLIGHT IDLE

Flight idle refers to the idle setting used when the thrust lever is set to idle while airborne (weight-off-wheels).

## ENGINE CONTROL SYSTEM (Cont)

### GROUND IDLE

N<sub>2</sub> ground idle is the minimum thrust setting. It is selected when weight is on wheels and the thrust lever is idle. Ground idle varies with altitude and temperature. Increases in altitude or ambient temperature result in an increase in N<sub>2</sub> idle rpm. Decreases in altitude or ambient temperature result in a decrease in N<sub>2</sub> idle rpm.

### REVERSE IDLE

When reverse idle is selected, reverse balk is activated by the FADEC. Further movement rearward beyond the REV detent is restricted until the thrust reverser is fully deployed.

### SINGLE ENGINE THRUST MANAGEMENT

The FADEC computers continuously crosstalk to share data on the health of each engine. The FADEC will automatically activate the APR function on the operating engine, should the other engine fail, as long as the TLA is in the TO detent or above and the APR has not been disabled by the crew.

The FADEC system monitors N<sub>2</sub> rpm of both engines. If the mismatch of N<sub>2</sub> speed exceeds 15%, the FADEC automatically increases the N<sub>1</sub> speed of the operable engine.

### AUTOMATIC POWER RESERVE

When an engine fails, the automatic power reserve (APR) feature of the FADEC will automatically increase the thrust for the operating engine to the emergency thrust power setting of APR power.

Automatic Power Reserve is available when APR is armed during takeoff if the thrust levers are in the TO detent or above and if APR has not been disabled by the crew. On the approach, APR is armed for the go-around when in approach configuration (either engine is available, flaps greater than 20°, or the landing gear is down).

APR power for both engines can also be selected by advancing both thrust levers to the APR stop. A cyan APR icon appears to the right of each N<sub>1</sub> indicator.

## ENGINE CONDITION AND FAULT REPORTING (ECFR)

An engine condition and fault reporting system is installed to provide monitoring of engine health. The system periodically records engine parameters and allows the crew to request that conditions be recorded at anytime. Use of the system entails downloading data from the FADEC for review by maintenance personnel. The data may be downloaded at anytime to assist in diagnosing engine problems which may be encountered. The ECFR is intended for maintenance functions and in-flight monitoring or diagnosis by maintenance personnel. The system is integrated into the FADEC of each engine.

### ECFR EVENT SWITCH

The EVENT switch is located on the engine control panel. The switch allows the flight crew to manually initiate data collection to the ECFR.

## ENGINE CONTROL SYSTEM (Cont)

### THRUST CALCULATIONS

FADEC automatically computes a target thrust rating for thrust lever position and presents the target or maximum value on the N1 indicator.

On the ground, normal rated takeoff thrust is automatically calculated when an engine is started. Normal rated N1 takeoff rpm is continuously updated for changes in the Mach number, delta ambient temperature, and pressure altitude.

During the takeoff roll, the N1 normal rated takeoff thrust value is continuously updated as the aircraft accelerates. At 65 kt discrete inputs for the thrust calculations are locked in. The calculation is unlocked when the aircraft altitude exceeds 400 ft. AGL or the thrust lever is retarded from the TO detent.

The cyan color target N1 appears on the N1 indicator as:

- N1 caret (doughnut for cruise power)
- N1 digital reference

-Thrust mode annunciation

### THRUST MODE ANNUNCIATION

The thrust mode annunciation identifies the position of the thrust lever during most phases of operation or a specific armed condition.

With both engines operating, the following thrust mode annunciations are presented:

- APR
- TO
- CLB
- CRZ
- REV

### MAX POWER (APR)

When either or both thrust levers are placed in the APR detent, the FADEC increases the engine thrust to automatic power reserve power (APR). The APR power setting is an emergency thrust setting.

To protect against inadvertent APR activation, the pilot must apply increased force to move the thrust lever forward to the APR detent.

APR thrust is indicated on the associated N1 gauge by:

- Cyan caret
- Cyan N1 digital reference
- Cyan APR icon

### AUTO APR FUNCTION

- AUTO APR function indications are the same as APR indications. If the aircrew elects to disable the AUTO APR function, an AUTO APR OFF (S) CAS message is displayed and the AUTO APR OFF switch is illuminated.

### NORMAL-RATED TAKEOFF N1 INDICATIONS (TO)

Normal-rated takeoff thrust is automatically calculated by FADEC when electrical power is applied to the aircraft on the ground. Takeoff thrust is set on the takeoff roll by placing the thrust levers in the TO detent.

The programmed normal-rated takeoff thrust value is displayed on the MFD by the following indications:

- Cyan caret
- Cyan N1 digital reference
- Cyan TO thrust mode annunciation for takeoff thrust

## ENGINE CONTROL SYSTEM (Cont)

### CLIMB THRUST (CLB)

When the thrust lever is placed in the CLB detent, the FADEC electronically programs the engine to accelerate or decelerate to the climb thrust setting.

The programmed climb thrust value is displayed on the MFD EICAS by the following indications:

- Cyan caret
- Cyan N1 digital reference
- Cyan CLB thrust mode annunciation

### CRUISE RANGE (CRZ)

Cruise power is unlike other thrust settings in that it is not associated with a thrust lever detent.

Cruise power is set by positioning the thrust lever in the quadrant range that exists between the IDLE and CLIMB detents. In this range, the pilot manually sets the thrust levers to maintain cruise speed or sets thrust for the descent and approach.

In cruise, FADEC does not set the cruise thrust to match the FADEC generated maximum cruise thrust target value. To distinguish maximum cruise power (CRZ) from other detent-related thrust settings, a cyan N1 doughnut is used instead of a caret.

Maximum cruise power (CRZ) is indicated by the following:

- Cyan doughnut
- Cyan N1 digital reference
- Cyan CRZ thrust mode annunciation

### BLEED AIR EXTRACTION

When the thrust levers are in any of the detents and a new bleed air demand is placed on the engines, the N1 target rpm may change to compensate for the new bleed-air demands.



# Challenger Global 300 - Power Plant

## N1 AND N2 SYNCHRONIZATION

### DESCRIPTION

OFF, N1, or N2, is selected with the AUTO SYNC switch, located on the ENGINE control panel. When SYNC (N1 or N2) is selected, the two engines are synchronized if the thrust levers are in the CRZ or CLB setting.

### COMPONENTS AND OPERATION

#### ENGINE SYNCHRONIZATION

When the AUTO SYNC selector switch is set to N1, the FADEC matches the fan speed of the slave engine to the speed of the master engine. The left and right engines will automatically designate themselves as master and slave engines using a cross-engine communication link. The engine with higher N1 compensation, or the left engine when N1 compensation of the two engines is the same, becomes the master engine. If the measured N1 or N2 of the slave engine is not within 5% of the master engine set point, the FADEC will provide an indication that synchronization is commanded but not achieved.

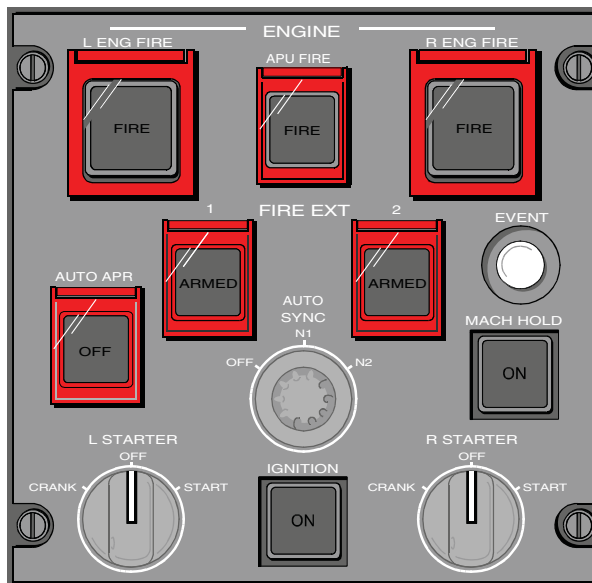

CFO1801002\_023

## THRUST CALCULATIONS (Cont)

### MACH HOLD

Mach hold is a function provided by FADEC that minimizes throttle movements over long periods during cruise. Limited adjustment is available to the master engine to hold the selected Mach. For MACH HOLD to be active, N1 or N2 must be synchronized, the aircraft trimmed for steady, level flight and the autopilot engaged in either Altitude Hold or Altitude Select (with altitude captured).

Mach Hold authority only allows N1 to be adjusted within  $\pm 3\%$  N1 for the thrust lever position at the time MACH HOLD is active. When active, a green MACH HOLD will be displayed between the N1 indicators (on aircraft without SV 6.0 upgrade and FADEC V-10 software, the green light will flash momentarily, then extinguish). At authority limits, a white MACH HOLD is displayed.

## ENGINE OIL SYSTEM

### DESCRIPTION

The engine oil system provides cooling and lubrication for all of the engine bearings, gears and splines. It also provides fuel heating and shaft vibration damping (through the use of hydraulic mounts). The engine oil sump venting and breather system is also integral to the overall lubrication system.

### COMPONENTS AND OPERATION

Oil is supplied to the engine by the oil pump that draws hot oil from the accessory gear box (AGB) oil tank. The oil is filtered and cooled in the fuel heater/oil cooler (FHOC) prior to flowing into the engine bearing sumps. In the engine bearing sumps (forward and aft) and in the AGB, the oil lubricates the bearings, seals, and gears and cools them by absorbing heat directly as it passes in and around these components. The oil is scavenged by dedicated scavenge pumps and returned to the oil tank. Power to drive the oil pump is provided by the compressor spool through the AGB.

An oil filter bypass valve and an impending bypass switch are located in parallel with the filter. The switch provides a warning when the filter becoming clogged and the pressure drop across it reaches 45 psi, indicating that impending bypass is imminent. The bypass valve opens at 65 psi. The ECU monitors the switch and the oil temperature, and provides an indication of impending filter bypass to the cockpit when the switch is open and oil temperature is in the normal operating range. During bypass mode, the system still provides a minimum filtration level by means of an accessible last chance screen. Once the impending bypass warning has been indicated, the CAS message remains illuminated during the bypass mode and logged by the FADEC to direct maintenance action prior to the next flight. Before oil is returned to the oil tank it flows across the chip detector in the AGB housing. The chip detector is linked to the ECU to provide an indication on the EICAS. Chip detector and impending oil filter bypass advisory CAS messages are presented as L (R) ENGINE OIL CHIP and L (R) ENGINE OIL BYPASS.

### ENGINE OIL PRESSURE INDICATIONS

To provide system redundancy, a pressure switch and separate pressure transmitter are used to monitor the engine oil pressure. When low oil pressure is detected by the pressure switch, a L (R) ENG OIL PRESS LOW (W) is presented. Excessively high oil pressure is indicated by a L (R) ENG OIL PRESS HIGH (C). An imminent bypass of the oil filter is annunciated by a L (R) ENGINE OIL BYPASS (A) CAS message.

## ENGINE OIL SYSTEM (Cont)

### ENGINE OIL LEVEL AND REPLENISHMENT SYSTEM

The engine oil servicing doors are located on the forward and left side of each engine nacelle. Oil quantity may be checked by a sight gage on the AGB and replenished through the oil filler port. The gage bands are marked FULL, ONE LOW, and NO DISPATCH. However, the primary means to check oil on the Challenger 300 is with the Remote Oil Level Sensor (ROLS). Oil levels are transmitted by the ARINC 429 bus to the refuel/defuel panel located in the right wing root fairing.

Wait at least 15 minutes, but not more than 1 hour following engine shutdown before checking the oil using ROLS, and service the tank if more than one quart (0.95 liter) low. Each engine oil tank capacity is 7.8 quarts (7.4 liters), while the oil volume at the FULL mark is 5.7 quarts (5.4 liters). The ONE LOW band indicates when the tank is approximately 1 quart below FULL. The NO DISPATCH band is approximately 1.6 quarts below FULL. If the oil level is *below* this band, the tank should be serviced prior to dispatch. However, if the oil level is within the band, the engine can be operated at least 10 hours without servicing the tank. The 10 hour time frame assumes a maximum engine oil consumption rate. Note that the oil volume is less than the total tank volume of 7.8 quarts (7.4 liters). The total tank volume design accounts for hot oil volume expansion and for the additional volume between the sight gage FULL mark and the fill-to-spill level.

**NOTE:** The oil level indication lights on the refuel defuel panel are for reference only. If the CHECK OIL light on the refuel defuel panel is illuminated, visually check the oil tank sight glass for dispatch ability.

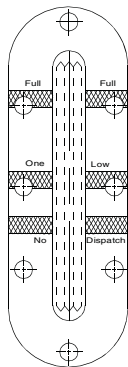

CFO1801002\_020

ENGINE NACELLE OIL LEVEL SIGHT GAGE

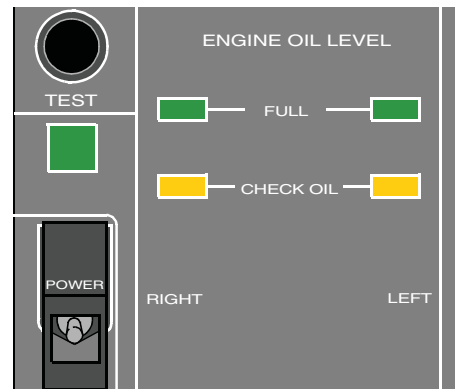

REFUEL DEFUEL CONTROL PANEL

### ENGINE OIL TEMPERATURE

Excessively high engine oil temperatures are displayed as L (R) ENG OIL TEMPERATURE HIGH (C) CAS message.

ENGINE OIL SYSTEM (Cont)

ENGINE LUBRICATION SCHEMATIC

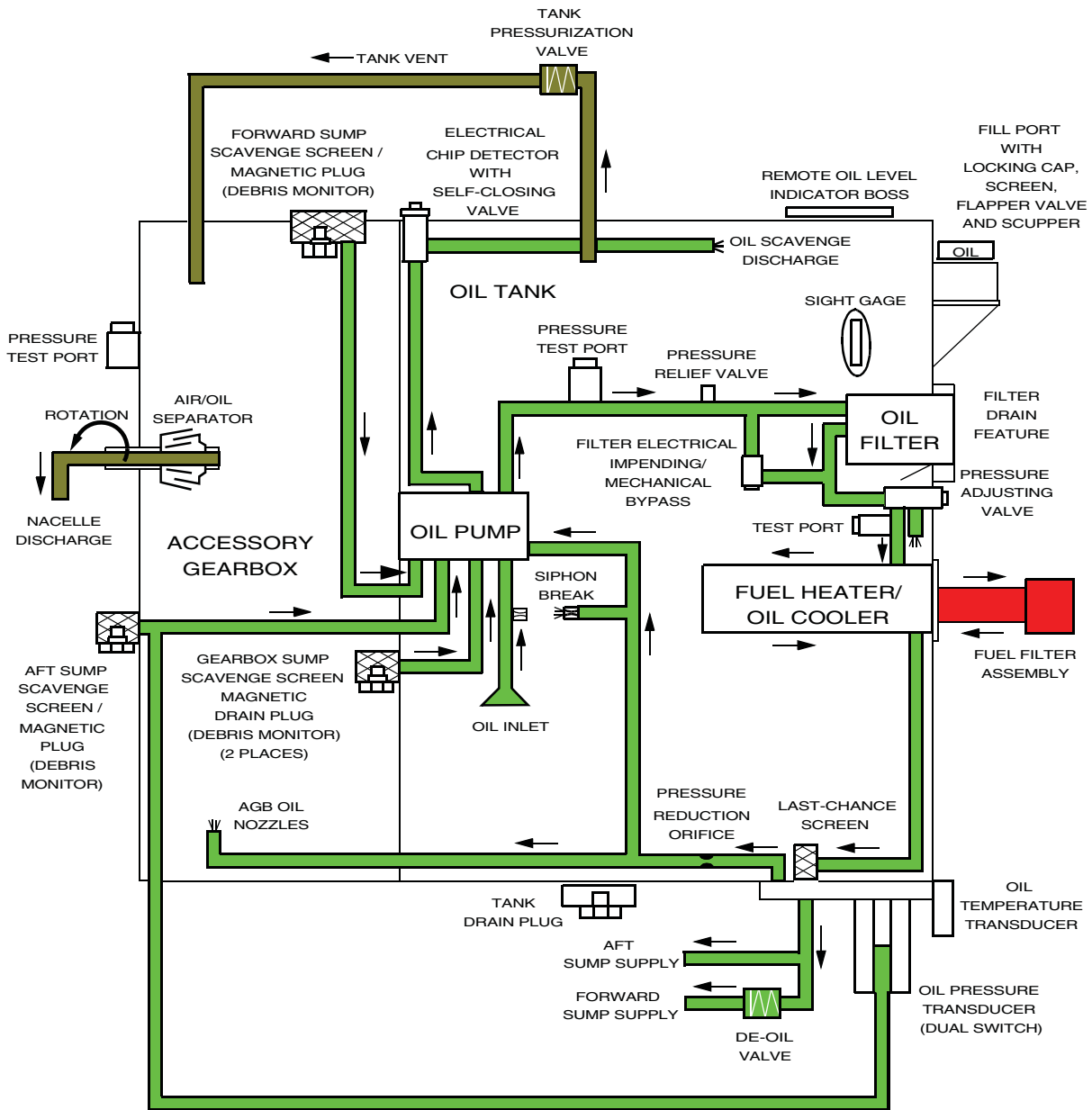

LEGEND

- VENT
- FUEL
- OIL

CFO1801002\_022

## ENGINE BLEED AIR SYSTEM

### DESCRIPTION

The engine bleed air system provides intermediate pressure (IP) air to the environmental control system and the opposite engine air turbine starter. It provides high pressure (HP) air to the wing and engine anti-icing systems.

The integrated air system management controller (IASC) controls bleed-air extraction from the engines. IASC 1 supports L BLEED and IASC 2 supports R BLEED functions.

Bleed-air is also extracted from the compressor by the surge bleed valves to regulate airflow through the engine core and is controlled by the FADEC.

L and R bleed-air selection, ON or OFF, is accomplished via the AIR COND/BLEED panel on the center pedestal. A cross-bleed valve is installed between the left and right pneumatic ducts, that can be opened automatically or manually by pressing the XBLEED push button, to provide bleed-air for engine starting. The APU is the normal source of bleed-air that is used for engine starting.

### COMPONENTS AND OPERATION

Engine bleed-air components consists of a bleed duct, intermediate pressure valve (IPV) and intermediate check valve.

Engine bleed-air duct assembly directs compressor bleed-air to the common bleed manifold that is located in the aft equipment bay. The engine compressor supplies bleed-air to operate the aircraft pneumatic system.

The nacelle bleed-air ducts are monitored for bleed-air leakage by the engine fire detection system.

Refer to Chapter 2, *Air Conditioning and Pressurization*, and Chapter 14, *Ice and Rain Protection* for more discussion on the bleed air system.

## ENGINE STARTING SYSTEM

### DESCRIPTION

The AS907-1 turbofan engine is equipped with an air turbine starter (ATS) and starter control valve. The start system is designed to achieve assisted ground starts, assisted inflight starts, and windmill inflight starts. Assisted starting can be accomplished with bleed air from the APU, an adjacent engine, or ground power. The engine also has an auto ignition function, which automatically provides ignition in the event of a stall, combustor blowout, or momentary loss of fuel. The starting system is used to accelerate the N2 high pressure section of the engine to a speed at which combustion light-off and self sustaining rpm occurs. Placing the engine run switch to RUN turns on the aircraft electrical boost pump. The START switch signals the FADEC to initiate the start sequence.

DC electrical power and air from the bleed-air manifold are required to open the start valve and engage the air turbine starter. The bleed-air manifold can be pressurized by the:

- APU bleed air
- Ground cart HP bleed air
- Opposite engine bleed air (crossbleed)

The pneumatic pressure from any of the three pneumatic sources is displayed on the ECS synoptic page.

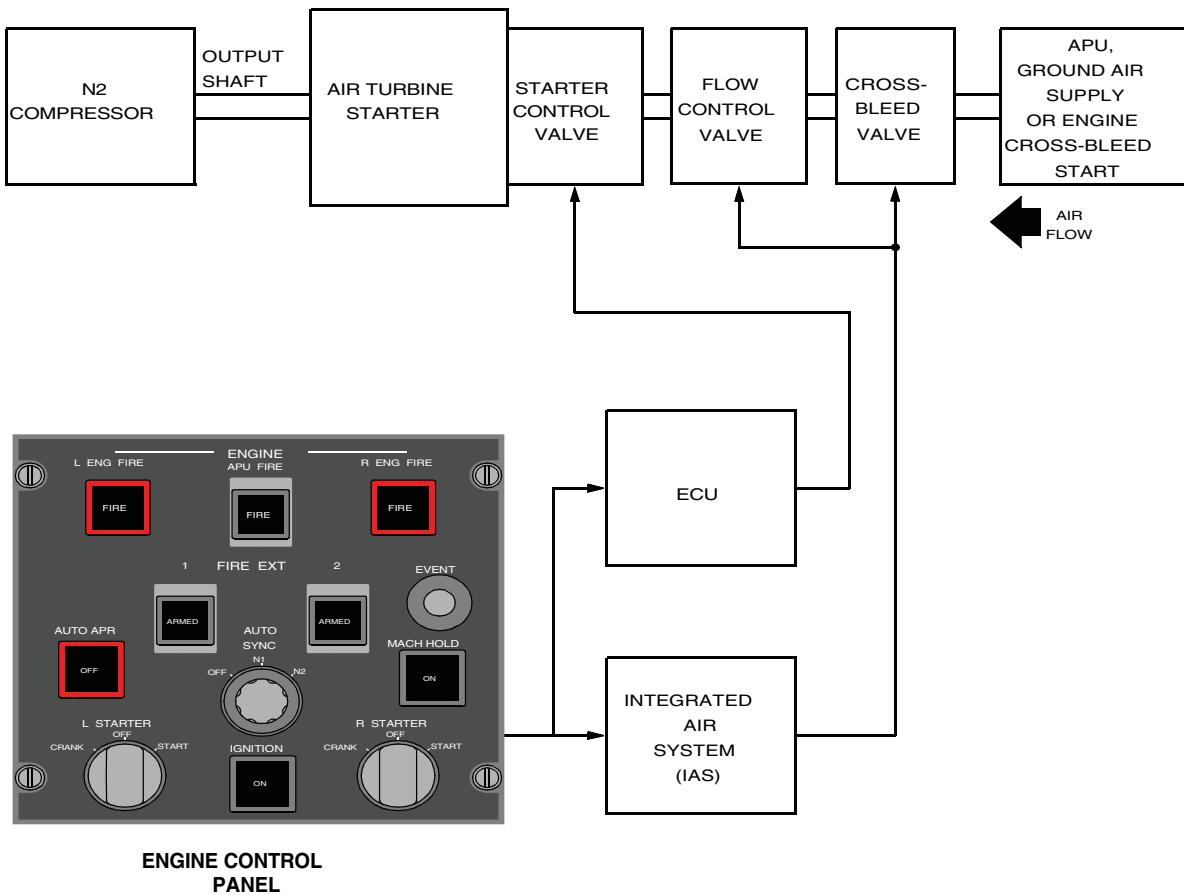

CFC01801002\_018

## ENGINE STARTING SYSTEM (Cont)

### COMPONENTS AND OPERATION

#### STARTER CONTROL VALVE

The starter control valve is mounted adjacent to the air turbine starter (ATS) inside the engine nacelle. The valve normally requires 28 VDC power and pneumatic pressure to open. When the L (R) starter switch on the ENGINE control panel is moved to the START position, the FADEC supplies 28 VDC power to energize the solenoid. This allows pneumatic pressure to open the valve and engage the air turbine starter.

When N<sub>2</sub> rpm is > 50%, the FADEC removes power from the solenoid, the start valve closes and the air turbine starter disengages.

#### AIR TURBINE STARTER (ATS)

The air turbine starter is mounted on the accessory gearbox. The ATS converts pneumatic energy into mechanical motion. The starter, through a sprag clutch, mechanically engages the accessory gearbox and assists in accelerating the engine to idle speed. During the start sequence, the start valve closes and the ATS disengages when the N<sub>2</sub> reaches or exceeds 46.2% or the OFF position is selected on the throttle quadrant assembly panel.

For subsequent starts, the starter sprag clutch does not require that the engine rotation be completely stopped before engaging the starter. The ATS may be engaged at any rpm up to 50% rpm (starter cutout speed).

#### START SEQUENCE

Each engine has a set of L (R) STARTER switches on the ENGINE control panel and a set of RUN/OFF switches on the throttle quadrant panel.

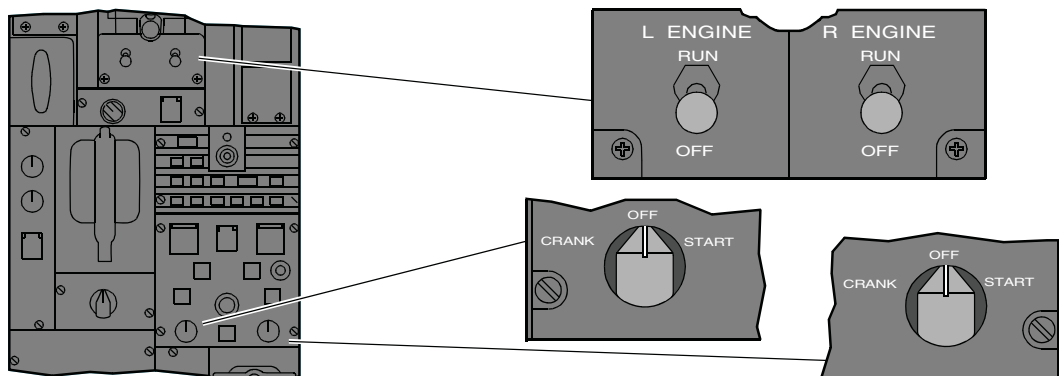

CFO1801002\_015

To start the engines, set the related engine switch to RUN. This turns on the fuel DC boost pump and operates the ECU start cycle. Set START switch to the START position and hold it for one second to operate the usual ground or air start.

When the applicable engine RUN position is selected on the TQA and the starter switch is set to START the:

- The start valve on the associated engine opens to allow pressure from the bleed air manifold to engage the ATS

When the engine's N<sub>2</sub> reaches 46.25%, the:

- The start valve closes and the ATS disengages

If the start valve fails to close after achieving 50% N<sub>2</sub>, a L (R) STARTER FAIL ON (C) CAS message is shown

Refer to the *Airplane Flight Manual* for starter limits.

## ENGINE STARTING SYSTEM (Cont)

### ENGINE MOTORING

Dry motoring is accomplished by toggling the start switch from OFF to CRANK and hold for the duration of the cranking. Dry motoring may become necessary to cool the engine when restarting the engine immediately after shutdown.

Wet motoring is accomplished by setting the RUN/OFF switch to RUN, toggling the start switch from OFF to CRANK and holding the latter for the duration of cranking. In response, the ECU energizes the air turbine starter control valve, controls the run solenoid, and controls the fuel metering valve per the start sequence.

A dry motoring follows the wet motoring start. Dry motoring is used to clear any pools of fuels that may have collected in the engine during the wet motoring.

## IGNITION SYSTEM

### DESCRIPTION

The ignition system consists of an ignition exciter, two igniter plugs, and two sets of igniter leads. The ignition system for each engine is a dual independent and redundant system. The ECU will activate the ignition system during automatic starts and restarts. The ECU will also automatically turn the ignition system off when the engine is running. The pilot can manually activate the ignition system by turning on the IGNITION switch.

For automatic ground starts, the ECU uses one ignition channel, changing the channel used on each start. For all other starts, both ignition channels are used simultaneously. The system is capable of continuous operation by manual activation by the pilot, but is normally only energized during the starting sequence.

### COMPONENTS AND OPERATION

#### ENGINE STARTING

When the FADEC in-control channel is determined during N<sub>2</sub> spool-up, the in-control channel closes the associated ignition relay. When the applicable L (R) ENGINE RUN switch is selected, the FADEC selected dc powered ignition exciter is energized. Ignition is de-energized by the FADEC at starter cutout.

#### AERODYNAMIC STALL

At an excessively high angle of attack (AOA), there is a possibility that turbulent airflow from the wing root could disrupt the flow of air into the engine intake. Disruption of airflow at the intake could lead to engine compressor stall. The FADEC and the stall protection computer provide two levels of compressor stall protection.

As the aircraft angle of attack reaches the stick shaker firing angle, the stall protection computer signals the FADEC to energize both ignition channels.

If the FADEC detects a compressor stall or surge, the FADEC will modulate engine thrust to clear the event.

## FLAMEOUT PROTECTION

If the FADEC detects an engine flameout, it will automatically initiate a re-light. Both ignitions systems are energized.

An engine flameout is detected when the following occurs:

- The engine is subidle and either the ITT rate of change is negative, or the N<sub>2</sub> rate of change is lower than commanded
- A flameout is detected while the engine RUN/OFF switch is still in the RUN position
- The L (R) ENGINE FLAMEOUT (C) CAS message is illuminated

When the affected engine's ENGINE RUN switch is placed in the OFF position, the L (R) ENGINE FLAMEOUT caution message is replaced by the L (R) ENGINE SHUTDOWN (S) message.



## THRUST LEVERS

### DESCRIPTION

The thrust lever quadrant contains the thrust levers, thrust reverse finger lifts, microswitches and internal locks and stops necessary to control the engines in forward and reverse thrust.

### COMPONENTS AND OPERATION

#### THRUST LEVERS

Thrust lever quadrant settings are MAX REV, REV, IDLE, CLB, TO, and APR. In addition, the range of movement of the thrust lever between IDLE and CLB is defined as the cruise range.

The thrust levers incorporate both mechanical stops and soft detents.

Self-centering soft detents prevent the thrust levers from moving inadvertently.

#### FRICTION KNOB

A friction knob allows the pilot to change the friction setting for the thrust levers.

#### THRUST LEVER POSITION MEASUREMENT

Actual thrust lever positions are electrically measured by rotary variable differential transformers (RVDTs) or sensed by micro switches that are housed within the thrust quadrant. The information is provided to the FADEC, the flight control computers (FCC) and to the data concentrator units (DCU). Other aircraft systems are influenced by thrust lever position are as follows:

- Landing gear warning system
- Takeoff configuration warning system
- Cabin pressurization
- Ground spoilers

#### TAKEOFF AND GO-AROUND (TOGA)

Takeoff and go-around (TOGA) switches are included in each thrust lever. When pressed, the TOGA switch signals the flight control computers to modify flight director commands and the FMS position is updated through the flight management computer(s).

#### THRUST REVERSE LEVERS

The thrust levers are linear throttles, which means that reverse thrust is not modulated by use of piggyback levers, instead, the thrust reverser levers are lifted above a gate, which allows the thrust lever itself to translate aft to modulate the reverse thrust level. The reverse thrust setting is for ground use only.

THRUST LEVERS (Cont)

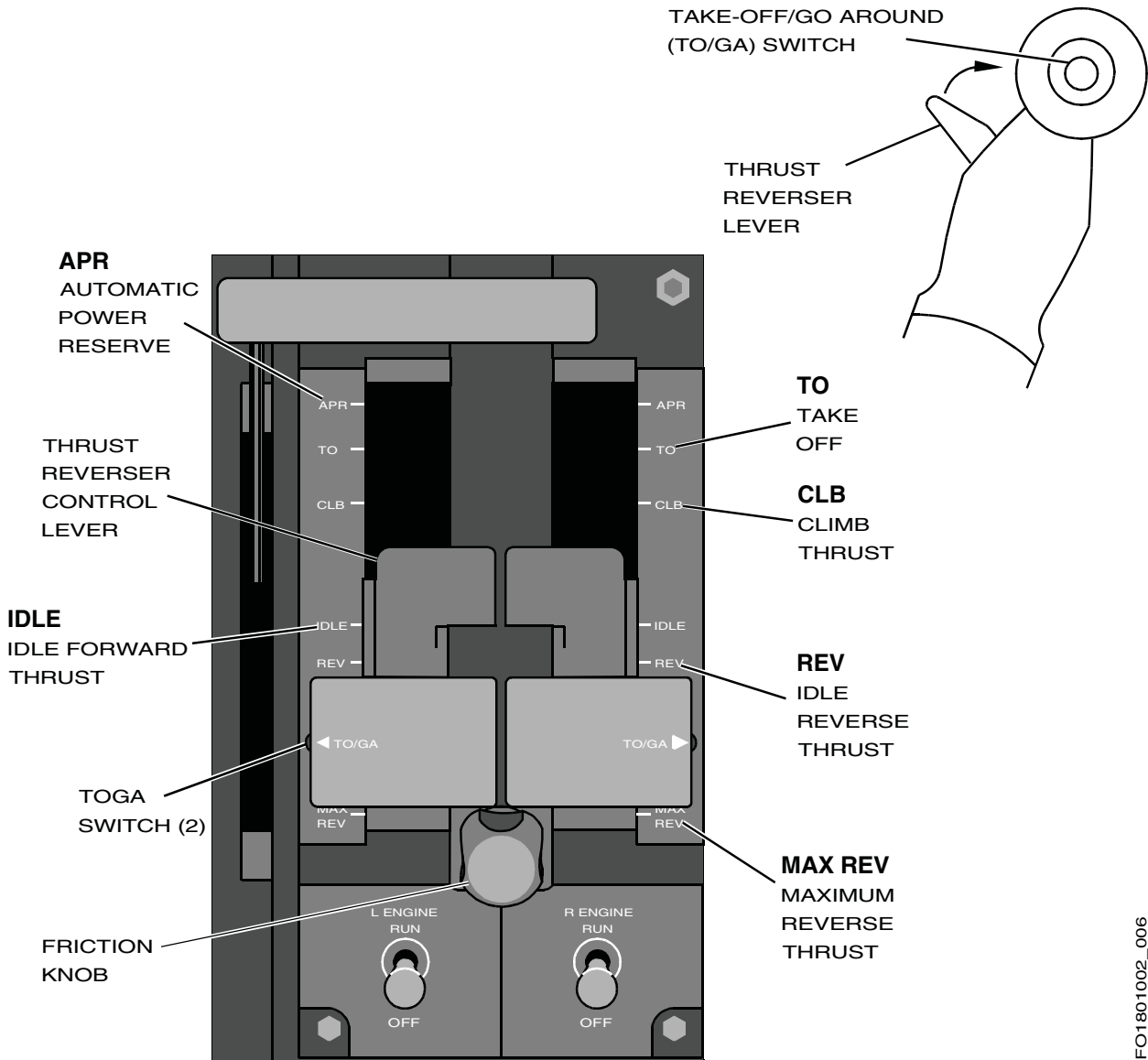

CFO1801002\_006

## THRUST REVERSER SYSTEM

### DESCRIPTION

The thrust reversers help stop the aircraft on landing and during a rejected takeoff (RTO). The system is operable on the ground only; the reversers will not deploy in flight.

### COMPONENTS AND OPERATION

#### THRUST REVERSER

The thrust reverser is powered by the left hydraulic system for the left reverser and the right hydraulic system for the right reverser and is controlled by the FADEC and electrical signals from the airplane.

The hydraulic system has:

- Isolation control unit
- Directional control unit
- Hydraulic and electro-hydraulic primary locks
- Door actuators
- Tertiary actuator locks

The electrical system comprises:

- Isolation control unit inhibition switch
- Stow switches — two per door, signal feedback to the FADEC
- Deploy switch — one per door, signal feedback to the FADEC
- Maintenance test switch — allows thrust reverser operation without engine operating

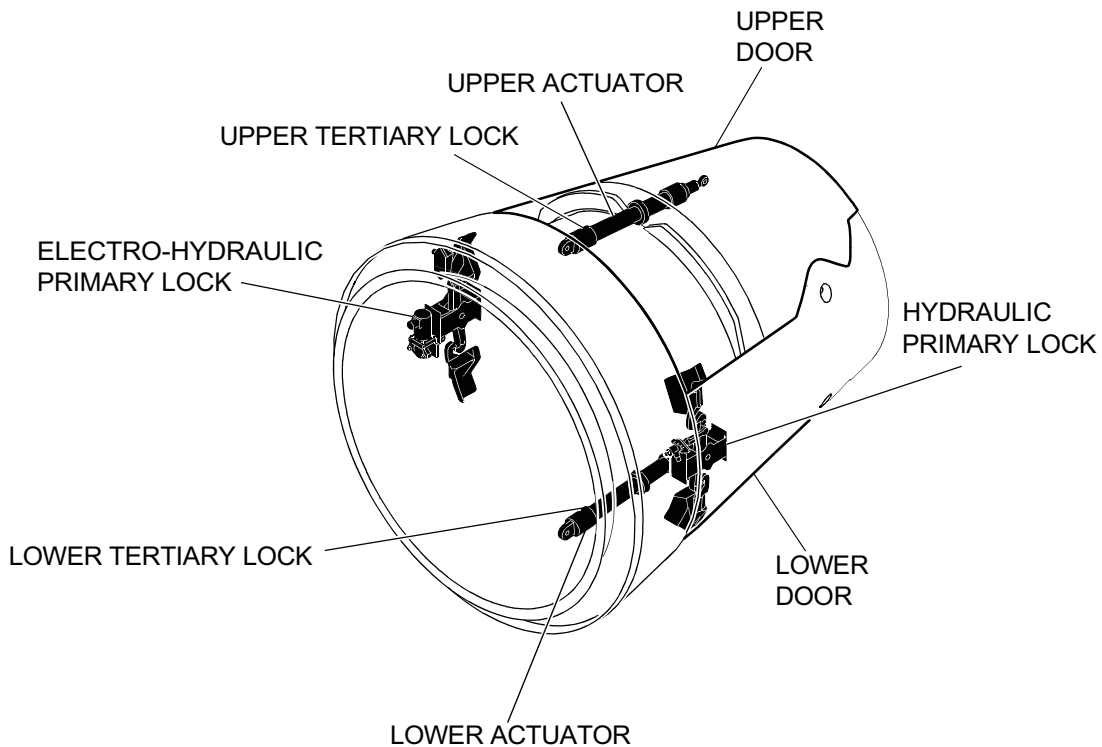

CFO1801002\_011

THRUST REVERSER SYSTEM (Cont)

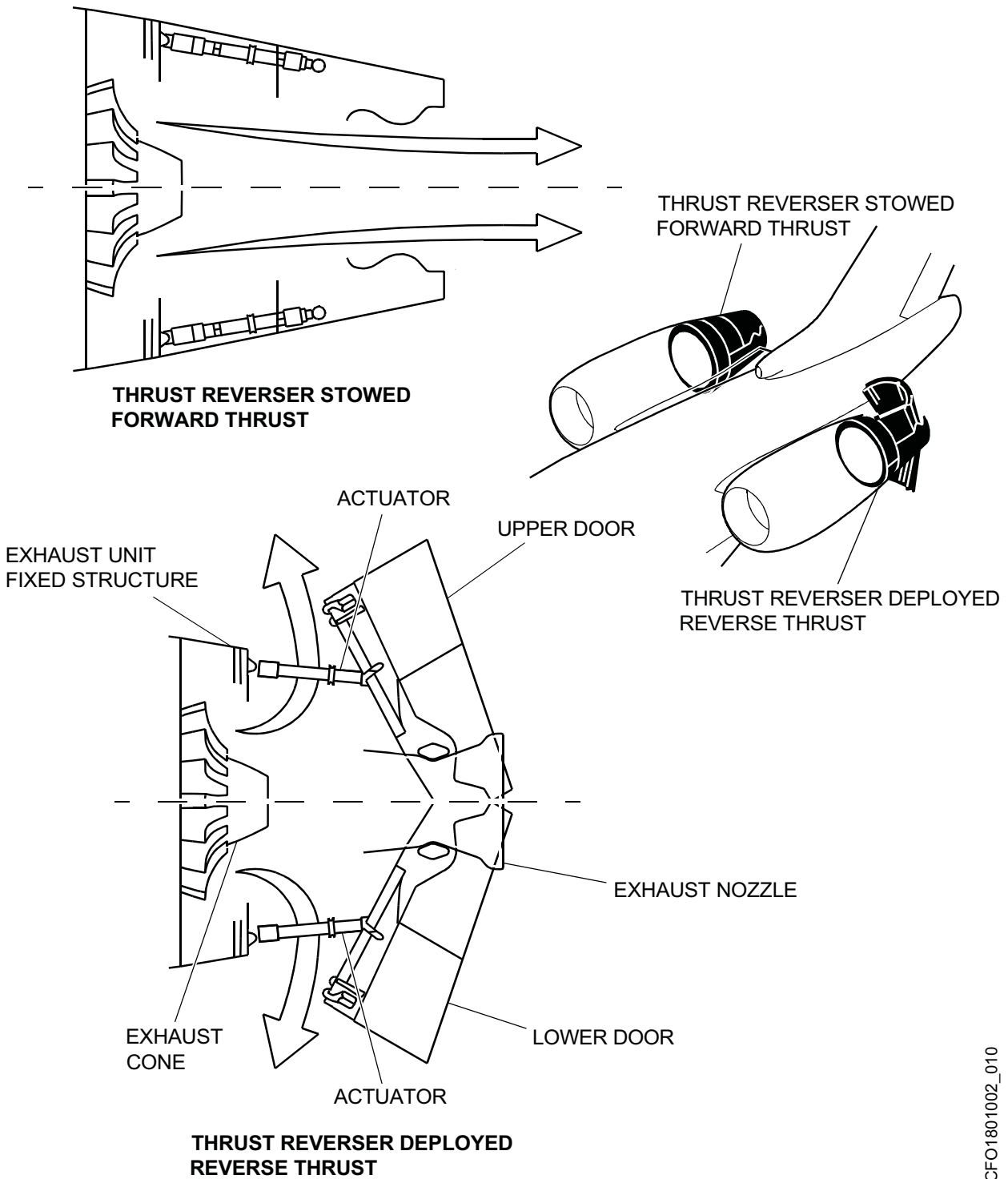

CFO1801002\_010

## THRUST REVERSER SYSTEM (Cont)

### REVERSE THRUST OPERATION

When reverse thrust is desired, the thrust levers are drawn aft to the IDLE position, where the thrust reverser levers may be lifted, thus allowing the main thrust levers to be pulled further rearward to the REV soft detent. This rearward movement signals the FADEC (via the RVDTs) and the thrust reversers (via the microswitches in the TQA) that thrust reverser deployment has been commanded. Once in the REV detent, it is unnecessary to hold the thrust reverse levers up, as they stay in place until the pilot selects forward operation. Interlock baulks will prevent movement of the levers rearward beyond REV until the thrust reverser deploy switches provide feedback that the thrust reverser doors are fully deployed. During the deployment sequence, a white REV icon is displayed on the EICAS, and N<sub>1</sub> target and bug are removed from the display. Once the doors are fully deployed, the REV icon changes to a green color, and the interlock baulk is released. This will allow for thrust lever modulation between the REV and MAX REV positions. N<sub>1</sub> target and bug are set to the maximum reverser N<sub>1</sub> setting.

To stow the thrust reversers, the main thrust levers are moved forward to the IDLE position. As the lever move between the REV and IDLE positions, the thrust reverser levers will return to their forward thrust position. Interlock baulks will prevent movement of the main thrust levers forward beyond IDLE until the thrust reverser stow switches provide feedback that the doors have completely closed. During the stow phase, the REV icon will go from green to white, and the N<sub>1</sub> target and bug are removed from the display. Once the doors are fully stowed, the REV icon will disappear, and the N<sub>1</sub> target and bug will reset to the takeoff setting. Also, the forward interlock baulk will be removed, allowing for forward thrust modulation above idle thrust.

Thrust reverser operation of each engine is independent of the other engine. If the FADEC senses that a thrust reverser door is unlocked in flight, the FADEC will limit engine thrust to idle, irrespective of thrust lever position. It will also post a L (R) REVERSER UNSAFE (W) CAS message. If the main thrust levers are pulled rearward to the REV position when the aircraft is not on the ground (no WOW or wheel spinup signal), the doors will not be unlocked, and an amber REV icon is illuminated inside the N<sub>1</sub> display. This caution signal is removed if the levers are restored to IDLE or forward while in the air.

### ISOLATION CONTROL UNIT

The isolation unit controls the hydraulic system pressure to the thrust reverser system.

### DIRECTIONAL CONTROL UNIT

The directional control unit controls hydraulic pressure to the upper and lower door actuators to deploy force.

A pressure switch sends a signal to the directional control unit. The directional control unit control also sends a signal to the upper and lower door actuators causing an overstroke of the thrust reverser doors to enable unlatching of the primary locks.

The unit contains a directional control valve that is controlled by a solenoid valve. The solenoid valve is controlled from thrust lever microswitches, WOW and wheel spinup signals. When the solenoid is energized, a deploy valve opens allowing hydraulic pressure to sequentially release the two primary locks.

Through the WOW or wheel spinup signal, two tertiary locks (prevents uncommanded thrust reverser deployment) release and allows the directional control valve to the deploy position.

As the aircraft decelerates, the maximum N<sub>1</sub> is reduced which limits thrust reverser authority and also helps prevent thrust reverser controllability problems.

**VIBRATION MONITORING SYSTEM**

**DESCRIPTION**

The vibration sensor is a self-generating velocity pickup design that outputs a voltage signal proportional to velocity. The signal is shared by both ECUs and annunciated in the cockpit.

**COMPONENTS AND OPERATION**

**VIBRATION MONITORING SYSTEM**

The powerplant fan assembly is continuously monitored for vibration. There is a vibration pickup on each engine, to provide feedback to the aircrew which engine is producing high vibration levels. It is also used by maintenance personnel for ground based fan trim balancing. A L (R) ENGINE VIBRATION (C) CAS message is illuminated and a VIB icon is displayed on the MFD. If there is a loss of vibration signals from the affected engine(s), a L (R) ENGINE VIB FAIL (A) is displayed as a CAS message.

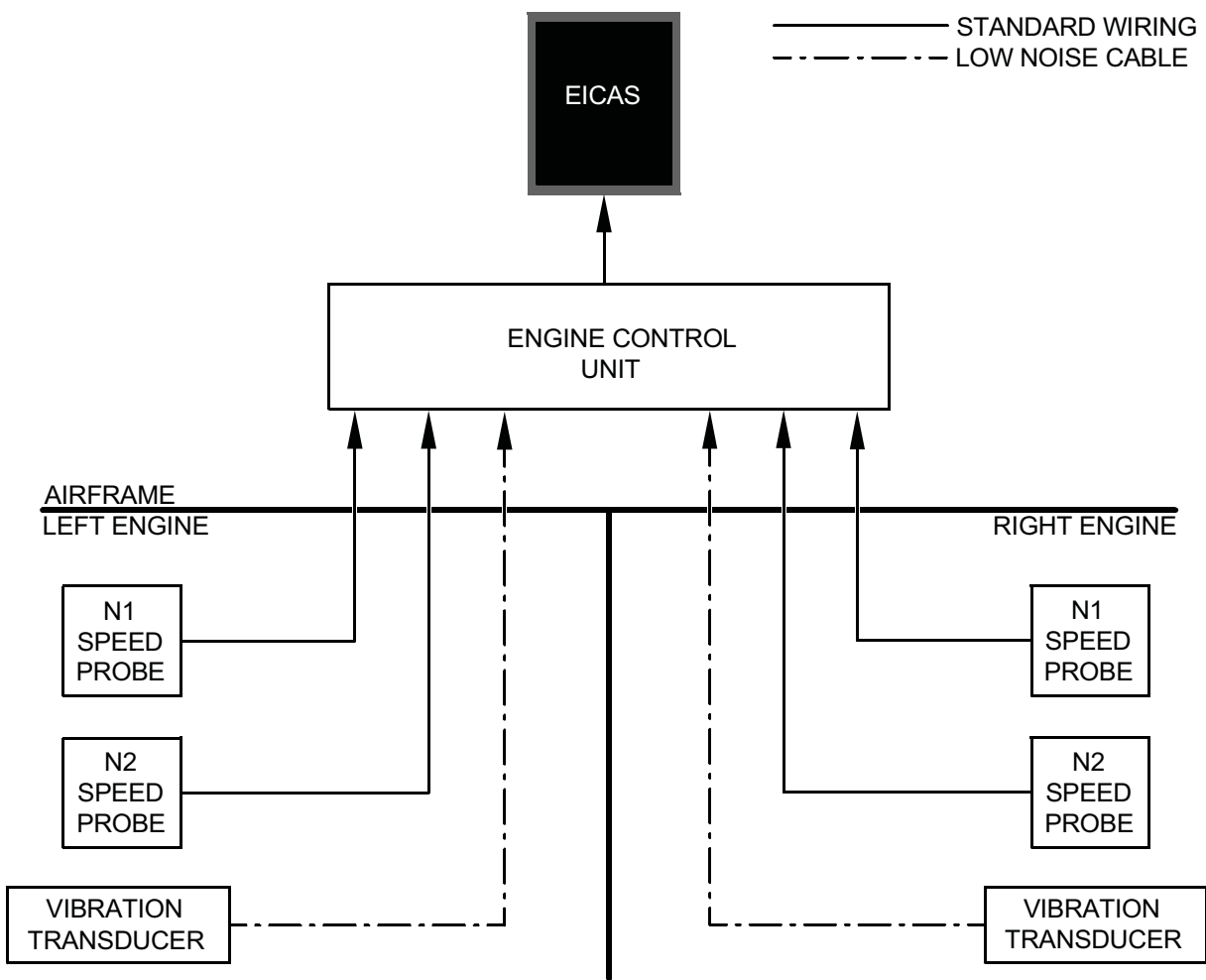

CFO1801002\_007

## CONTROLS AND INDICATIONS

### DESCRIPTION

The thrust levers control the application of forward and reverse thrust.

TOGA switches provide data for other operating systems.

The ENGINE panel provides switches to control engine starts, continuous ignition, Mach hold, engine synchronization, disabling of the auto APR function, as well as fire extinguishing.

Engine-operating parameters are presented on the EICAS display. Indications include N1 and N2 (in percent values), as well as ITT, fuel flow, oil pressure and temperature, ignition system and start status, high engine vibration levels, thrust reverser use, as well as the selection of engine synchronization and mach hold.

### THRUST LEVER QUADRANT AND ENGINE CONTROL PANEL

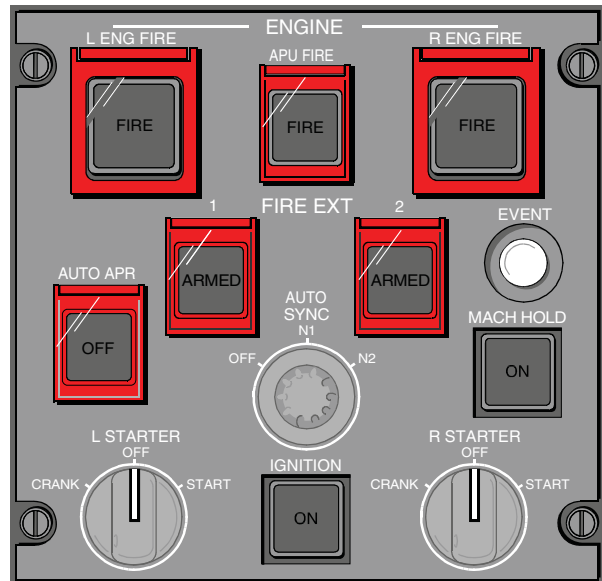
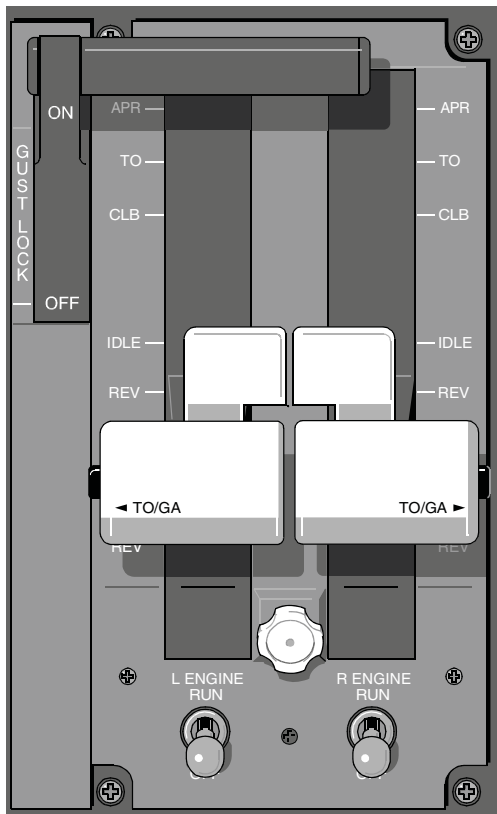

CFO1801002\_023

# Challenger Global 300 - Power Plant

## CONTROLS AND INDICATIONS (Cont)

### ENGINE START CONTROLS

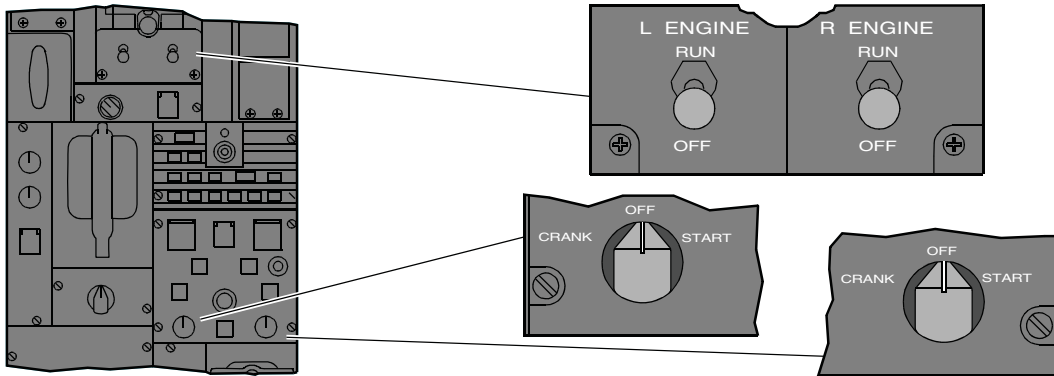

CFO1801002\_015

### AIR COND/BLEED CONTROL PANEL

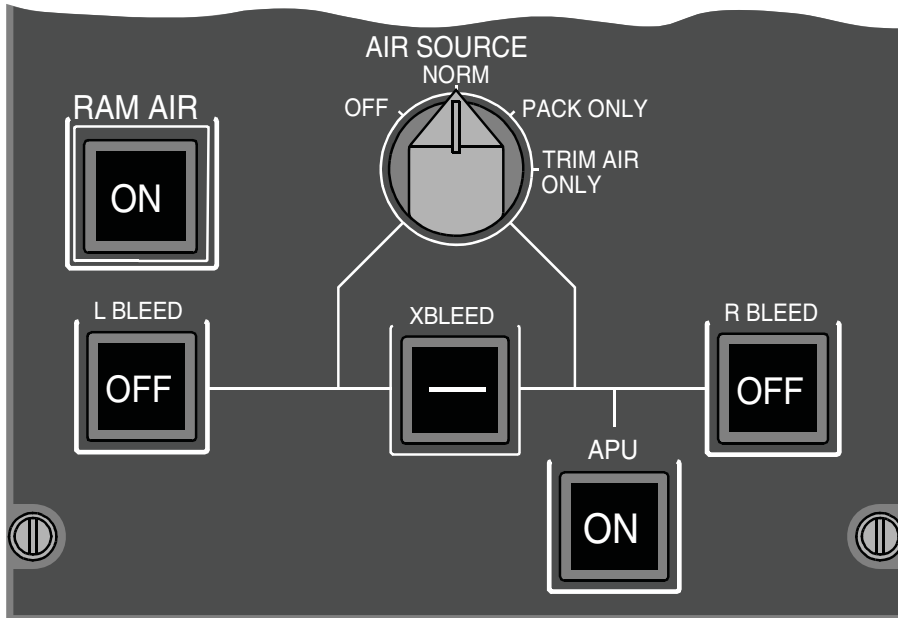

CFO1801002\_003

### EICAS DISPLAY

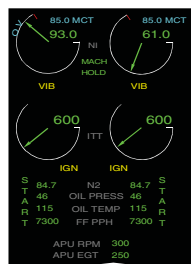

CFO1801002\_017



## Challenger Global 300 - Power Plant

### EICAS MESSAGES

The powerplant messages are shown on the EICAS. In the table below are the powerplant messages, meanings, inhibits, and aural warnings along with a brief explanation of each message.

MESSAGE	INHIBITS	MEANING	AURAL WARNING
L (R) ENGINE EXCEEDANCE		The respective engine has exceeded a speed or temperature limit	
L (R) ENGINE FIRE		The L (R) ENGINE FIRE CAS, FIRE EI in the N1 indicator, FIRE indication in the L(R) ENG FIRE switch, or "LEFT (RIGHT) ENGINE FIRE" voice message indicates that the engine fire detection loop has activated. An engine fire is usually accompanied by other indications, such as: excessive ITT, erratic or rough engine operation, fluctuating engine indications, or smoke in the cabin.	"Left (Right) Engine Fire"
L (R) ENG OIL PRESS LOW	TO/LAND	The respective engine oil pressure is low	
L (R) REVERSER UNSAFE		Illumination of either the L or R REVERSER UNSAFE CAS, or a REV EI indicates an unsafe thrust reverser condition. The affected engine should automatically decelerate to idle. The autostow function will attempt to stow the reverser doors	
L (R) ENGINE FLAMEOUT		The respective engine has had a flameout	
ENGINES FUEL BYPASS	TO/LAND	Both engine fuel filters are impending bypass	
L (R) ENG OIL TEMP HIGH	TO/LAND	The respective engine oil temperature is high	
L (R) ENG ANTI-ICE FAIL	TO/LAND	The respective engine anti-ice has failed	
L (R) ENG DSPL MISCOMP	TO/LAND	The respective engine N1 or ITT display does not agree with the other N1 or ITT display	
L (R) ENG FUEL SOV FAIL	TO/LAND	The respective engine fuel shutoff valve has failed to close when commanded	
L (R) ENG OIL TEMP HIGH	TO/LAND	The respective engine oil pressure is low	
L (R) ENG OIL PRESS HIGH	TO/LAND	The respective engine oil pressure is high	
L (R) ENGINE VIBRATION	TO/LAND	A higher than normal level of vibration has been sensed in the respective engine	

## Challenger Global 300 - Power Plant

MESSAGE	INHIBITS	MEANING	AURAL WARNING
L (R) FADEC FAIL	TO	Major control system failure affecting both channels of the respective FADEC. The engine may shutdown or got to idle, or engine operation may be degraded. Failure of the control system may cause control effect, performance degradation or a loss of a protective system	
L (R) REVERSER FAIL	TO	The respective thrust reverser has failed	
L (R) START ABORTED	TO/LAND	The ground engine start on the respective engine has been aborted	
L (R) STARTER FAIL	TO/LAND	The respective engine starter has failed	
L (R) STARTER FAIL ON	TO/LAND	The respective engine starter has failed ON	
DOWNLOAD FADEC	TO/LAND	The FADEC maintenance data should be downloaded	
ENG SYNC/M-HOLD FAIL	TO/LAND	Engine SYNC and Mach hold are not available	
L (R) ENG A/ICE FAIL ON	TO/LAND	The respective nacelle anti-ice has failed ON	
L (R) ENG FUEL TEMP LOW	TO/LAND	The fuel temperature in the respective engine filter is low	
L (R) ENG IGN FAULT	TO/LAND	A fault has been detected in the respective engine ignition	
L (R) ENG THRUST FAULT	TO/LAND	A fault has been detected in the respective engine thrust	
L (r) ENGINE FAULT	TO/LAND	A fault has been detected in the respective engine	
L (R) ENGINE FUEL BYPASS	TO/LAND	The respective engine fuel filter is impending bypass	
ENG MACH HOLD FAIL	TO/LAND	The Mach hold function has run out of authority	
L (R) ENGINE MINOR FAULT	TO/LAND	The engine has detected a minor engine fault	
L (R) ENGINE OIL BYPASS	TO/LAND	The respective engine oil filter is impending bypass	
ENGINE SYNC FAIL	TO/LAND	The engine sync mode has failed	
L (R) ENG VIBRATION FAIL	TO/LAND	Loss of vibration signal from affected engine	

## Challenger Global 300 - Power Plant

<b>MESSAGE</b>	<b>INHIBITS</b>	<b>MEANING</b>	<b>AURAL WARNING</b>
L (R) ENGINE ANTI-ICE FAULT	TO/LAND	Anti-ice bleed over-pressure detection, may result in higher ITT than normal	
L (R) ENGINE OIL CHIP	TO/LAND	Metal debris detected in engine lube system	
AUTO APR OFF		Auto APR has been selected off	
L (R) ENGINE SHUTDOWN		The respective engine has shutdown with the RUN switch OFF or the respective FIRE switch pushed	
L (R) REVERSER INOP		The respective thrust reverser is inoperative and is mechanically pinned, hydraulically and electrically isolated	